

# Mearlcrete®

**Lightweight Insulating Concrete Roof Decks**

*Specify MEARLCRETE for your next project:*

- *Superior Wind Uplift*
- *Positive Drainage*
- *Sustainability*
- *Best Initial & Life Cycle Cost*



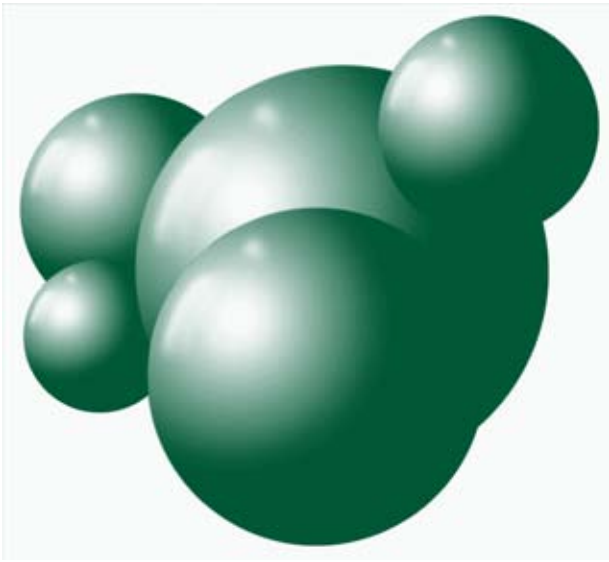

**M**EARLCRETE® enables the manufacturing of lightweight cellular concrete at the jobsite by mixing Portland cement-water slurry with the Mearlcrete engineered preformed foam. The unmatched stability of Mearlcrete preformed foam enables MEARLCRETE lightweight insulating concrete (LWIC) to be pumped greater distances, mixing more efficiently, while maintaining precise density control. Mearlcrete LWIC does not require a high water to cement ratio to maintain excellent workability.

MEARLCRETE can be applied over non-vented substrates including existing roof membranes, galvanized vented or non-vented steel deck, precast concrete, or cast-in-place structural concrete. MEARLCRETE LWIC placed over metal deck can be used to enhance the shear diaphragm providing additional resistance to shear forces resulting from wind or seismic activity.

MEARLCRETE has excellent workability. It can be pumped over 500 ft. vertically and over 1,000 ft. horizontally. MEARLCRETE is installed by factory trained contractors who have the specialized equipment and experienced personnel to install high quality MEARLCRETE decks. Single source roof warranties are available when installed by an authorized Mearlcrete applicator.

MEARLCRETE insulating roof decks are superior to rigid board insulation systems. MEARLCRETE LWIC is not subject to thermal drift or thermal bridging. The insulating values and history of performance of a MEARLCRETE LWIC system provides unmatched life-cycle cost and performance.

*Mearlcrete was chosen on these jobs for its superior uplift ratings and sustainability.*



## SYSTEM

MEARLCRETE LWIC can be placed over precast or cast-in-place concrete, and galvanized steel decking. In all of these systems, the inclusion of insulation board increases R-values and reduces dead load. System weights can be as low as 7 psf.

## EPS INSULATION BOARD

When combined with EPS, MEARLCRETE Roof Decks have advantages over other roofing deck systems:

- A solid base for roofing membranes
- Reduced dead weight
- Custom slope-to-drain capability
- Superior fire and wind uplift ratings

## ROOFING

Roofing may begin when the roof deck can withstand foot traffic, which is from one to two days after the deck is cast. The presence of random shrinkage cracking is not detrimental to the roofing system.

## THE ROOFING BASE SHEET

The roofing base sheet is attached with an approved base sheet fastener to the MEARLCRETE LWIC Roof Deck in

a pattern recommended by the roofing manufacturer. Fastener pullout values increase with the age of the roof deck. Typical nail withdraw is 40 pounds.

## PERIMETER VENTING

Perimeter venting at the flashing/counter flashing detail should be a part of the roof system, although it is not necessary in low humidity regions. Special bottom-side venting provisions are not normally required, unless local practice requires it.

## FOR SINGLE-PLY ROOFING

For single-ply roofing, consult the manufacturer for specific recommendations. Modified bitumens may be torched or mopped to a nailed base sheet or directly adhered to the MEARLCRETE LWIC.

## FULLY ADHERED ROOFING

Singly-ply membranes that are either plain or fleece-backed can be adhered to the MEARLCRETE LWIC roof deck by a roofing manufacturer's designated adhesive.

## INSULATION VALUES FOR CORRUGATED STEEL AND CONCRETE SUBSTRATE DESIGNS

Thickness of Expanded Polystyrene Board (Inches)	U-Factor No Ceiling Heat Flow		Total Weight Steel Deck EPS Board MEARLCRETE		U-Factor No Ceiling Heat Flow		Total Weight 4" Deck EPS Board MEARLCRETE	
	Up	Down	(PSF)	Factor	Up	Down	(PSF)	Factor
1	.123	.117	5.44	7.0	.119	.113	54.6	7.3
2	.081	.078	5.52	11.2	.079	.077	54.7	11.5
3	.060	.059	5.60	15.3	.060	.058	54.8	15.6
4	.048	.047	5.68	19	.048	.047	54.9	19.8
5	.040	.040	5.76	23.7	.040	.039	55.0	24.0
6	.034	.034	5.84	27.8	.034	.034	55.1	28.1

## Mearlcrete Roof Deck - Physical Properties

Wet Density lbs/ft <sup>3</sup> (1)	Dry Density lbs/ft <sup>3</sup>	Compressive Strength lbs/in <sup>2</sup> (2)	R-Factor °F (BTU/hr. sq. ft.) per in. Thick
30	25	140	1.49
35	29	210	1.32
40	34	330	1.15
45	38	450	1.02

### NOTES:

1. Weight of roofing not included.
2. Weights and R-values include the metal deck and the Mearlcrete deck system.
3. Minimum 2" thickness of MEARLCRETE Cellular Concrete over EPS board at a cast density of 35 pcf.
4. Includes both inside and outside air films and roofing membrane.
5. 4" structural concrete deck (140pcf) weight 50 psf.
6. Conventional 4 ply BUR add 6 psf. single ply add 2-7 psf. See steel deck table for additional information.
7. Weights and U-factors may vary depending on the steel used and structural concrete design.
8. The U-factors shown are for uniform thickness of insulation.

# MEARLCRETE PLACEMENT

## Typical Sloped Lightweight Insulating Concrete for New or Reroof Construction

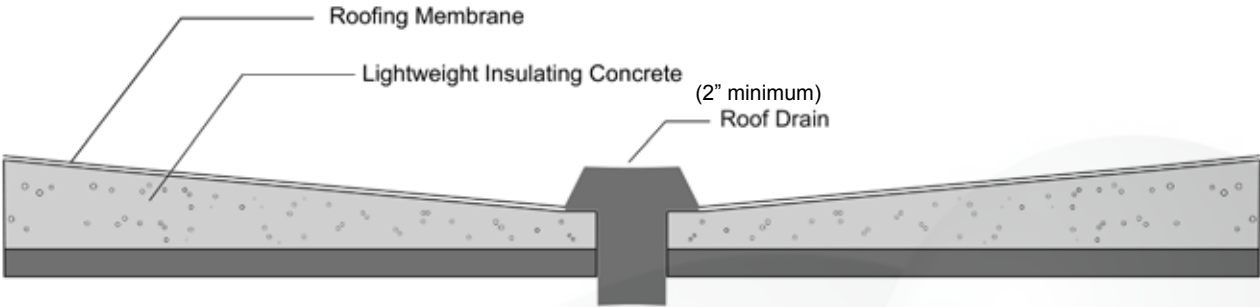

Lightweight Insulating Concrete (without EPS Board)

## Typical Sloped Lightweight Insulating Concrete for New or Reroof Construction

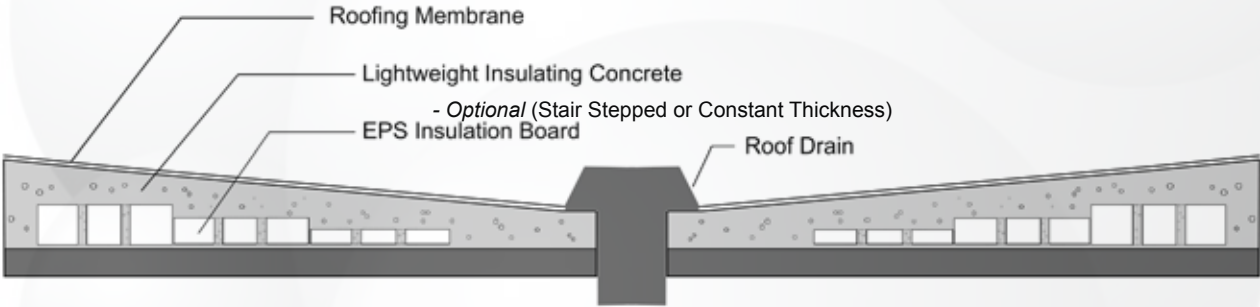

Lightweight Insulating Concrete (with EPS Insulation Board)

## Typical Sloped Lightweight Insulating Concrete for Reroof Construction

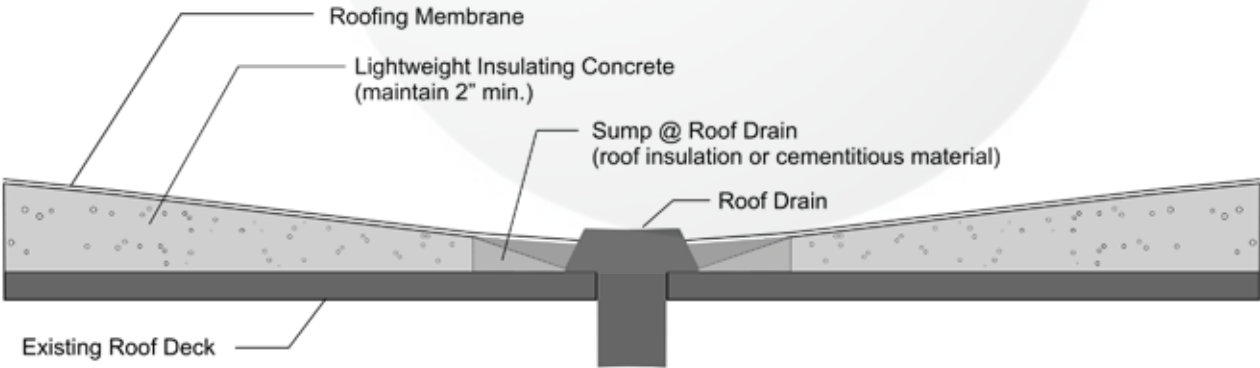

Lightweight Insulating Concrete (Roof Drain less than 2" above deck)

# ARCHITECTURAL SPECIFICATIONS

## 1. Overall

1.1 Description of work. Provide an insulating concrete roof deck system as shown on the drawings and as needed for a complete and proper installation.

1.2 Applicator qualification. The Applicator shall be approved by the Manufacturer - Cellular Concrete Solutions.

1.3 Certification. When required and upon completion, a certificate from the Manufacturer and Applicator states that the materials and installation methods follow current practices.

1.4 Data. Prior to start of the work, present installation procedures, and submittals, as required, for fire ratings and wind uplift data for this application.

## 2. Materials

2.1 Insulating concrete is a mix of cement, water, and MEARLCRETE engineered preformed foam to produce an insulating concrete of a specific density range. The engineered preformed foam concentrate shall meet ASTM C869 the LWIC tested in accordance with ASTM C796.

2.2 Cement. Portland cement shall comply with ASTM C150.

2.3 Water. Use potable water.

2.4 Aggregate. For hybrid mixtures, the expanded mineral aggregate shall comply with ASTM C332, Group I.

2.5 MEARLCRETE approved admixtures for water reducing and set acceleration may be used.

2.6 Physical properties shall meet the following criteria: Cast density of 34-42 pcf, minimum compressive strength of 160 psi. Cast density of 42-48 pcf, minimum compressive strength of 250 psi.

2.7 Insulation Board. When included, the EPS insulation board shall conform to ASTM C578 Type I board, and be of thickness shown on the drawings. EPS board shall have bond holes equal to approximately 3% of the board area. The board is placed in a slurry coat and topped with a minimum 2" of MEARLCRETE LWIC. The EPS board may be stair-stepped or of constant thickness.

2.8 Expansion joints are necessary when there are expansion joints in the structural system. Control joint filler is not necessary at vertical protrusions.

## 3. Execution

3.1 Inspection. Prior to starting work, any unsatisfactory conditions of related trades shall be corrected by others.

3.2 Installation. Install the insulating concrete roof deck system in accordance with current practices to insure proper drainage, the required insulation value, and the published fire and uplift ratings.

3.2.1 Preparation. General Contractor shall clear the deck of all standing water, dirt, debris, ice, etc.

3.2.2 Mixing and placing. Insulating concrete is mixed in approved equipment and pumped into place. EPS bond coats, double casting, and two-density casting may be acceptable methods of installation.

3.2.3 Finishing. Screed the insulating concrete to the proper thickness and slope. The surface shall be free of ridges and sharp projections prior to installation of the roofing membrane.

3.2.4 Weather. Insulating concrete roof decks may be placed when temperatures are 32° F and rising. If colder temperatures are anticipated, the Applicator shall take suitable precautions (heated water, etc.) for the installation of an acceptable deck. Coordinate the roofing membrane application with the insulating concrete installation to avoid prolonged exposure of the roof deck.

3.2.5 Testing. Check the cast density at the point of placement and adjust the mix to obtain the required cast density. *Please see NRDC A 250 'Field Quality Control Procedures for Application of Insulating Concrete Roof Deck Systems'.*

3.3 Completion. Roofing may begin when the roof deck can withstand foot traffic and specified fastener pull out is achieved, which is from one to two days after the deck is cast. This facilitates curing and reduces drying shrinkage. Protect the insulating concrete roof deck from construction traffic. It is recommended that the roof deck should not be left exposed for longer than 5 to 7 days. The Applicator cannot be responsible for rain (moisture) entering the roof deck after the deck is cast and finished. The general contractor and roofing contractor are responsible for removing excess water in the system. Consult the roofing membrane manufacturer for their recommended nailing pattern or adhesive for securing the roofing membrane to the roof deck system.

## MEARLCRETE APPROVALS

### Approvals:

- Factory Mutual Approved
- Underwriters Laboratory Approved
- Dade County, Florida – #08-0902.06
- New York City Board of Standard/Appeals (Docket 680-58-SM)
- U.S. Army Corps of Engineers – CEGS-03510  
Roof Decking, Cast-In-Place Low Density Concrete



### Technical Staff Membership Representati

- American Concrete Institute
- American Society of Civil Engineer
- American Society for Testing and Materials
- National Roof Deck Contractors Association
- Florida Roof Deck Association
- Roof Consultants Institute

## ALWAYS GREEN

Since 1945, Cellular Concrete Solutions has been committed to reducing waste. With all of the focus on the environment today, we are proud to say that our product has been a green product since the beginning. Our commitment to innovation and product improvement have led to more environmentally friendly products and applications.

## SUSTAINABLE OPTION

Cellular Concrete Solutions lightweight Insulating Concrete Systems have proven to be valuable elements of sustainable building design. The two primary components of lightweight insulating concrete systems, Portland cement and expanded polystyrene, combine to create a reroofable deck. Because it is reroofable, lightweight insulating concrete is consistent with sustainable building design philosophies. Additionally, by increasing long-term thermal efficiency, lightweight insulating concrete helps reduce energy resource requirements.

In a lightweight insulating concrete system, Portland cement is combined with pre-generated foam to form a lightweight fill. Expanded polystyrene board is encapsulated in the lightweight fill, resulting in an engineered composite system that functions as a monolithic substrate for the roof membrane, and potentially functions as a contributor to the structural diaphragm component of the building envelope. This multiple functionality demonstrates an efficient use of materials, contributing to the goals of sustainability and environmental sensitivity.

## REDUCING CARBON EMISSIONS

Incorporating the advanced foam generation systems designed by the Innovations Lab of Cellular Concrete Solutions will significantly reduce the trucking and mining that is required for typical pervious or non pervious fill applications.

## LEED CREDITS

MEARLCRETE Insulating Concrete Roof Decks have been used on many LEED approved projects. MEARLCRETE Roof Decks may assist with the following LEED points (LEED-NC Green Building Rating System for New Construction and Major Renovation Version 2.2 - October 2005):

### **MATERIALS & RESOURCES**

**MR Credits 1.1 and 1.2:** Consider reuse of existing, previously occupied buildings, including structure, envelope, and elements. Maintain 75% of existing walls, floors & roof (Maintain 95% for MR Credit 1.2). *(1 or 2 points possible)*

**MR Credits 3.1 and 3.2:** Use salvaged, refurbished, or reused material, products, and furnishings for at least 5% (10% for Credit 3.2) of building materials. *(1 or 2 points possible)*

**MR Credits 4.1 and 4.2:** Use materials with recycled content such that the sum of post-consumer recycled content plus one-half of the pre-consumer content constitutes at least 10% (for MR Credit 4.1, 20% for MR Credit 4.2) of the total value of materials on the project (based on cost). *(1 or 2 points possible)*

**MR Credits 5.1 and 5.2:** Use building materials or products that have been extracted, harvested, or recovered, as well as manufactured within 500 miles of the project site for a minimum of 10% (for MR Credit 5.1, 20% for MR Credit 5.2) of the total materials value (based on cost). *(1 or 2 points possible)*

### **ENERGY & ATMOSPHERE**

**EA Prerequisite 2:** Design the building to comply with ASHRAE/IESNA Standard 90.1-1999 (without amendments) or the local energy code, whichever is more stringent. *(Required)*

**EA Credit 1:** Reduce design energy cost compared to the energy cost budget for energy systems regulated by ASHRAE/IESNA Standard 90.1-1999 (without amendment), as demonstrated by a whole building simulation using the Energy Cost Budget Method. *(1-10 points possible, depending on improvement in proposed building performance rating over baseline building performance rating).*

Some of our other products include:

**Mearl Geofoam™ 60 Non Pervious** - for grouting and low-density, geotechnical construction applications

**Mearl Geofoam™ 60 Pervious** - for pervious lightweight concrete applications

**Cell Flow™** - for the production of CLSM materials

**Mearlcell™ 3532-40** - for precast applications

**Mearl Transport™** - for the transportation of mine tailings, sand and other materials



## CELLULAR CONCRETE SOLUTIONS®

MEARLCRETE® DIVISION

7020 Snowdrift Road, Suite 102 ● Allentown, PA 18106

Toll free: (888) 235-5015 ● Phone: (610) 398-7833 ● Fax: (610) 398-7050

www.cellular-concrete.com ● info@cellular-concrete.com